

USE AND CARE GUIDE

QBD[®]

VISI COOLER

**MODELS: DC3H, DC4H, DC6H, DC6HG,
DC7H, DC7HG DC10HB, DC12HB**

CONTENT	PAGE#
Introduction	2
Important Use and Safety Instructions	3
Operating Your Visi Cooler	4
Preparation, Care and Cleaning	5
Installation Requirements	6
Wiring Diagrams	7-8
Reversing the Door Swing	9
Shelf Stopper Clip Mounting Instruction	10
Pallet Removal Instruction	10
Door Handle Installation Instruction	11
Questions? Problem Solver	12
Questions? Service Providers, Warranty	12

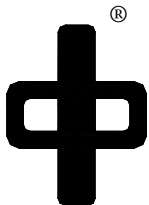

QBD Cooling Systems Inc.

31 Bramstele Rd., Brampton, Ontario, Canada L6W 3K6 Tel: (905) 459-0709 Fax: (905) 459-1478

**Read this book carefully...**

It is intended to help you operate and maintain your new cooler properly. Always keep it handy.

If you don't understand something or need more help, please write or phone to:

Manager, Customer Service,
QBD Cooling Systems Inc.
31 Bramsteele Road,
Brampton, Ontario,
Canada L6W 3K6

Tel. 1(905) 459 0709
1(800) 663 3005
Fax. 1(905) 459 1478
Web Page- <http://www.qbd.com>

We are proud of our service and want you to be pleased. If for some reason you are not happy with the service you receive, here are two steps to follow for further help.

FIRST, contact the people who serviced your cooler. Explain why you are not pleased. In most cases this will solve the problem.

NEXT, if you are still not pleased, write all the details - including your phone number to QBD's above address or fax. at: 1(905) 459 1478 or call : 1(905) 459 0709 ; 1(800) 663 3005.

E-Mail- info@qbd.com

If you received a damaged cooler . . .

Immediately contact the carrier that delivered you the cooler for all your claims.

All goods are shipped at the customers risk.

Return of goods to the factory must have the authorized approval of QBD.

No returns will be accepted after 10 days.

Any shortage claims must be made within 5 days of receiving the goods.

How to unpack your cooler. . .

DC3, DC4, DC6 and DC7 - First remove all the outer packing material on the cooler. Then dismantle the skids at the base by tilting the cooler to one side [right]. Use a Philips screwdriver to remove the two screws on the wooden base. Repeat the same operation by tilting the cooler to the left hand side . Push the wooden blocks away and your unpacked cooler is on its feet....

DC10, DC12 - For pellet removal instructions, see page 8

Save time and money. Before you request service. . .

Check the Problem Solver in the back of this book. It lists the minor operating problems that you can solve yourselves.

Write down the model and serial numbers.

You will see them on a label in the cooler. Please write these numbers and the purchase date here:

Model Number: _____ **Serial Number:** _____ **Purchase Date:** _____

Please use these numbers and the date in any correspondence or service calls concerning your cooler.



Read all instructions before using this appliance.

- This cooler **must not** be stored outdoor or in ambient conditions where the temperature may exceed **105° F (41°C)**, or in **direct sunlight**.
- This cooler is designed to be used **indoor only**, in ambient conditions of **65°-90° F (18°-32°C)** with **60%** relative humidity.
- **Use this cooler only for its intended purpose** as described in this Use and Care Guide. This equipment is intended for the storage and display of non-potentially hazardous, bottled or canned products only.
- **For trouble free operation, it is recommended that the condenser be cleaned every 1 to 2 month. Failure to clean condenser can cause compressor malfunction and VOID WARRANTY.**
- **For compliance to the NSF sanitation requirements DC7 cooler must be mounted in one of the following ways:**

1. Sealed to the counter top.

The lower perimeter of the cooler cabinet must be sealed to the counter top using flexible PVC baseboard trim.

This baseboard trim is available from your local lumber –hardware supplier or from QBD’s order desk. A PVC baseboard trim with a self-adhesive back is ideal for this application.

The baseboard trim will be applied to the complete perimeter of the cooler except for the area around the lower door hinge. The hinge is not sealed to the counter top to facilitate maintenance and servicing.

The baseboard is pressed tightly against the vertical wall of the cooler while the lower edge of the baseboard trim is pressed downward against the counter top and thereby providing a tight seal around the base of the cooler.

Because of the flexibility of the PVC baseboard trim a good seal is achievable on counter tops that are curved or bowed.

OR

2. Elevated on legs that provide a minimum clearance of 10cm (4 in) beneath the unit.

*Optional NSF Certified legs are available from QBD’s order desk. Ask for QBD part number 47-0530-204. Four (4) legs per cooler are required.

WARNING ! When using this appliance, always exercise basic safety precautions, including the following:

- **This cooler must be properly installed in accordance with the Installation Instructions before it is used.** See grounding instructions and the Installation Sections.
- **Never unplug your cooler by pulling on the power cord.** Always grip plug firmly and pull straight out from the outlet.



- **Repair or replace immediately all electric service cords that become frayed or otherwise damaged.** Do not use a cord that shows cracks or abrasion along its length or at either the plug or connector end.
- **Unplug the cooler before cleaning and making repairs.**
Note: We strongly recommend that any servicing be performed by a qualified Technician.
- **Before replacing a burnt out lamp, the cooler should be unplugged** in order to avoid contact with a live wire filament. [A burned out lamp may break when being replaced.]
Note: Turning the control to the OFF position does not remove power to the light circuit.
- **Do not store or use gasoline or other flammable vapors and liquids in the vicinity of this or any other appliance.**



Energy - Saving Tips. . .

Location of your cooler is important. Avoid locating it next to a vent or where the sun will shine directly on the appliance.

Close the door as soon as possible, particularly in a hot and humid weather.

Keep back of the cooler minimum 3 in.(76. mm) away from the wall.

Clean Condenser frequently, every 1 to 2 month.

Temperature Control Dial

The temperature control dial has settings from 1 to 9 plus “OFF”.

1 is the warmest setting.

9 is the coldest setting.

Initially set the temperature to the recommended setting shown on the label at the internal cabinet serial-name plate.

After using the cooler for 24 hours, adjust the temperature control to the setting that is best suited for your needs.

NOTE : If the cooler is unplugged or turned off, you must allow 3 minutes before starting it or plugging it back in. If you attempt to restart it in less than 3 minutes, it may not restart and it may damage the compressor and **VOID WARRANTY.**

Turning the temperature control dial to “OFF” stops cooling but does not shut off power to the cooler.

Shelves

Shelves in DC3H, DC4H, DC6H/DC6HG, DC7H/DC7HG, DC10HB and DC12HB can be moved to different levels to suit your varying storage needs.

See page 8 for shelf stopper clip mounting instructions, specific to DC10HB and DC12HB.

Leveling Legs

Adjustable legs at the front should be set so that the cooler is firmly positioned on the countertop or floor. Turn leveling legs counterclockwise to raise the cooler, clockwise to lower it.

Note :

Do not raise the front wheels of the DC10, DC12 more than 1/16”



Location

The cooler must be installed on a level floor, strong enough to support it when it is fully loaded.

Free standing

DC3, DC4, DC6, DC7, DC10 and DC12 are designed for freestanding installations only. They should not be recessed or built-in.

Clearances

Allow the following clearances for ease of installation, door opening and proper air circulation:

Top	2"
Hinge Side.....	1 1/4"
Non Hinge Side.....	1/2"
Back.....	3"

Preparing to Move

Disconnect the power cord from wall outlet and remove the product. Then clean and dry the interior.

Secure all loose items such as shelves by taping them securely in place to prevent damage.

Be sure cooler stays in upright position during actual moving. Cooler must be secured in transit to prevent movement. Protect outside of cooler with a blanket.

Note : Never transport the cooler without using the manufacturing skid or pellet and door support bracket, this will prevent damage to the door and cooler in transit.

Preparing to shut down the cooler

For an extended period of absence, unplug the cooler. Clean the interior with baking soda solution of one tablespoon of soda to one quart of water. Wipe dry. To prevent odors, leave an open box of baking soda in the cooler. It will also help to leave the door (s) open.



Unplug the cooler and remove all products and shelves. Wash inside with warm water and baking soda solution - about one tablespoon of baking soda to a quart of water. Then rinse and dry.

Don't use cleaners such as soaps, detergents, scouring powder or spray cleaners - they may cause odors inside the cooler.

Wash shelves in mild detergent solution and dry with a soft cloth.

To help prevent odors, leave an open box of baking soda in the rear of the cooler, on the shelf. Change the box every three months.

Wipe outside of the cooler with a soft cloth dampened with soapy water. Use only mild, soapy water to clean the door gasket.

Notes:

- Never use acids, chemical thinner, gasoline, benzene or the like for cleaning any part of the cooler. Boiling water or benzene may deform or damage plastic parts.
- Failure to keep the condenser coil clean and unobstructed at all times will result in poor cooling and possibly damage and **VOID WARRANTY**. Clean condenser with a bristle brush or vacuum. Disconnect power to unit prior to cleaning.

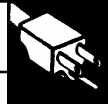
**IMPORTANT! Please Read Carefully****How to connect electricity ?****For personal safety, this appliance must be properly grounded.**

The power cord of this cooler is equipped with a three-prong (grounding) plug which mates with a standard three-prong (grounding) wall outlet to minimize the possibility of electric shock hazard from this appliance. Have the wall outlet and circuit checked by a qualified electrician to make sure the outlet is properly grounded. If you have only a standard two-prong wall outlet, it is your personal responsibility and obligation to have it replaced with a properly grounded three-prong wall outlet.

DO NOT, UNDER ANY CIRCUMSTANCES, CUT OR REMOVE THE THIRD (GROUNDING) PRONG FROM THE POWER CORD.

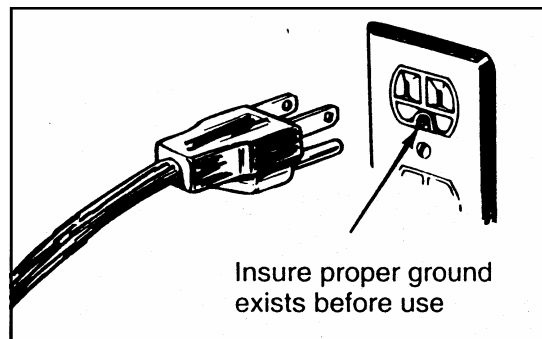
**Electrical Requirements**

The cooler should always be plugged into its own individual electrical outlet which has a voltage rating that matches the rating plate.

This provides the best performance and also prevents overloading the wiring circuits that may cause a fire hazard from the overheated wires.

Use of Extension Cords

Because of potential safety hazards under certain conditions, we strongly recommend against the use of an extension cord.

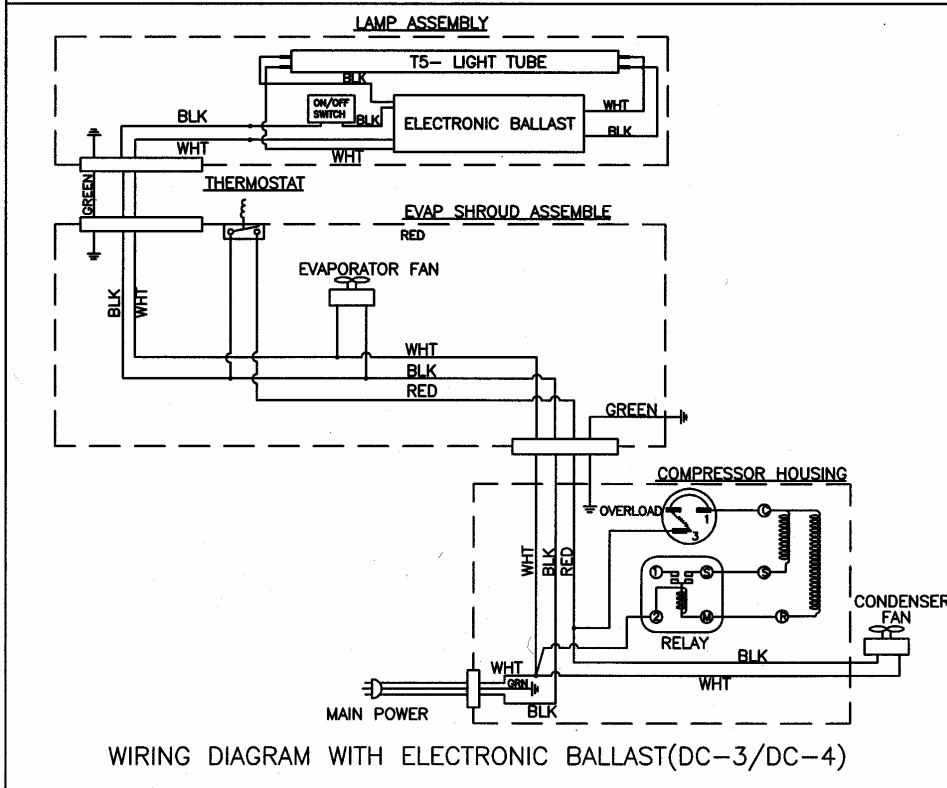
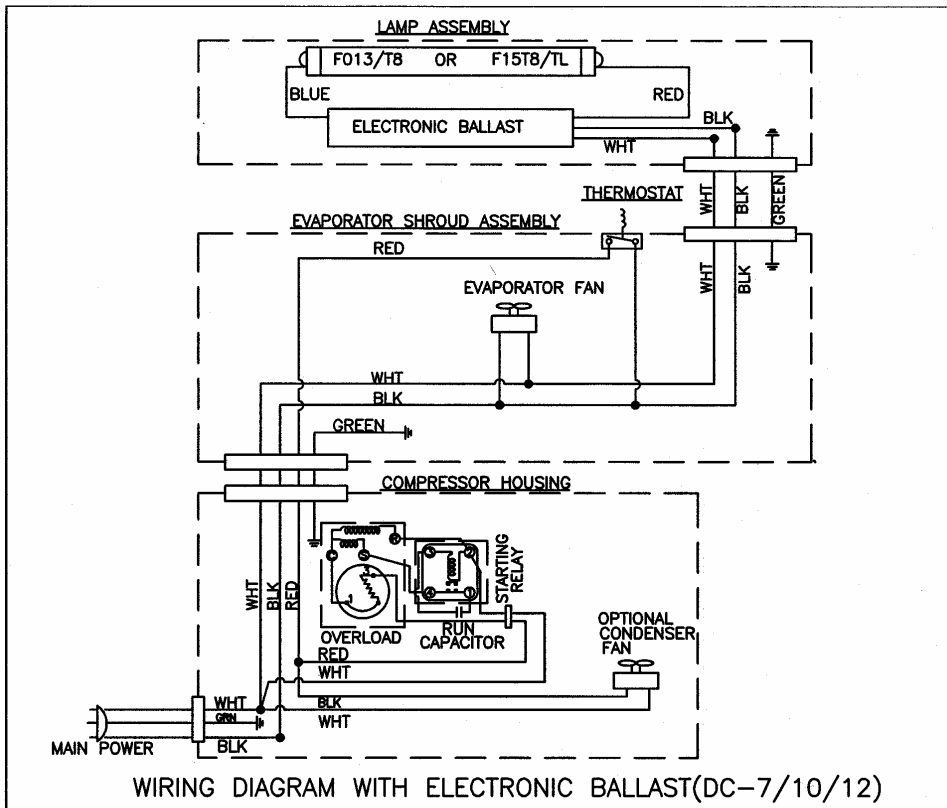



To change the door hinges from the right side of the cooler to the left:

1. Unplug the cooler and empty it.
2. Do not remove the leveling legs.
3. Use a Philip type screwdriver to remove the top bracket while holding the door. If there is a shim under the bracket, remove it too. Set the bracket aside but take care to hold the door.
4. Open the door slightly and lift it up firmly. The spring would be released at the bottom.
9. Place the door on a flat non-scratching surface. Interchange the door's top and bottom pivot pins by removing and fixing

5. DC3, DC4, DC6, DC7	DC10, DC12
Tilt the cooler approx. 6" to the back and block the front bottom so as to allow the use of a Philips screwdriver.	Lay the cooler on it's side and remove the front wheels as the wheels must be removed before the bottom bracket can be removed.

the two

6. Remove the bottom bracket and if there is a shim under the bracket remove it too.
7. Remove the bronze bushing from the bottom bracket and fix it in the other hole of the bracket.

8. DC3, DC4, DC6, DC7	DC10, DC12
Re-install the bottom bracket on the left side. Remove the front block and rest the cooler in it's rite-up position. Do not disturb the door handle.	Re-install the front wheel , NOTE: front wheel spacer must be placed in the back of the bottom bracket to keep the wheel level. Rest the cooler in it's up-rite position and do not disturb the door handle.

screws.

10. Remove the bronze bushing from the top bracket and fix it in the other hole of the same bracket.
11. Remove and re-insert the plastic plugs for the screw holes on the cooler top from the left side to the right side holes.
12. Set the door on the cabinet through the bronze bushing in the bottom bracket and reinstall the top bracket on the left side supporting the door.
13. Tilt the cooler back once again as in step 5. Fix spring at the left bottom in the door pivot pin slot. Pre-load the spring by giving (1) full turn for the DC6 and DC7 and (2 ½) for the DC10, DC12. Swing the door to test the proper operation. Also remove the brand logo from the bottom of the door and refit at the right hand top corner of the door.

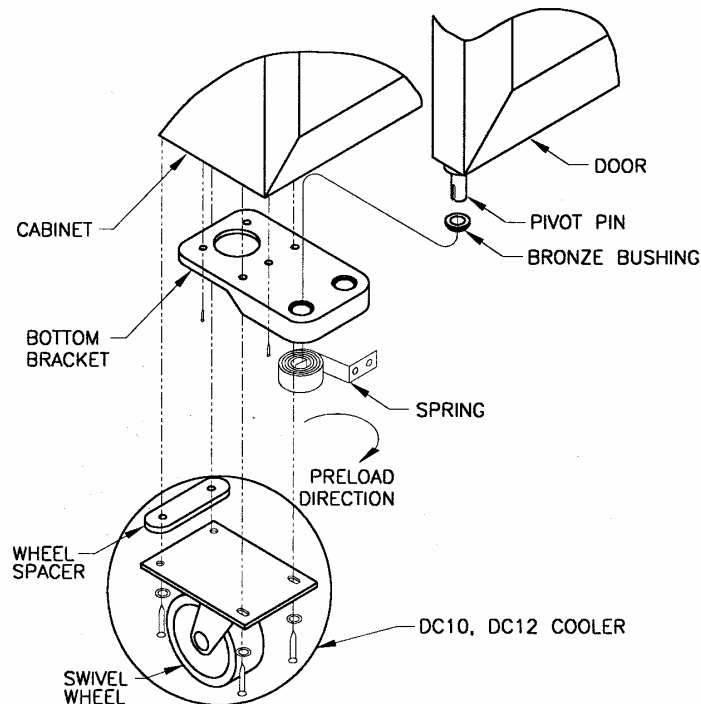

QBD^{ch!} SHELF STOPPER CLIP MOUNTING INSTRUCTIONS



1. Load shelf into cooler (Fig. A)
2. Snap supplied stopper clip onto shelf between middle support and the molded cooler shelf support (Fig. B)
3. Repeat for other side of shelf and for all other shelves.
4. Snap supplied price sticker holder onto center of shelf.
5. Repeat for all other shelves.
6. Stopper clips and price sticker holders are typical for all types of shelves.

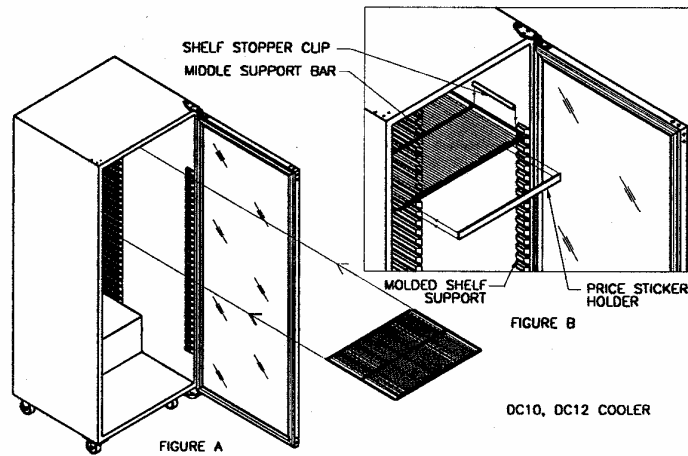

QBD^{ch!} PALLET REMOVAL INSTRUCTIONS



1. Remove plastic wrap and side cardboard.
2. Open the door.
3. Remove the two screws and front door support shipping bracket (Part A in Fig. 1) and discard both the screws and front shipping bracket.
4. Close the door.
5. Remove the screws from the back shipping bracket (part B in Fig. 2) and discard both the screws and back shipping bracket.
6. Using a flathead screwdriver, separate wheel stopper (Part C in Fig. 2) from base plate (Part D in Fig. 2) and discard the stopper.
7. Once parts are separated, carefully roll cooler off pallet in the direction of the arrow shown in drawing and discard the pallet.

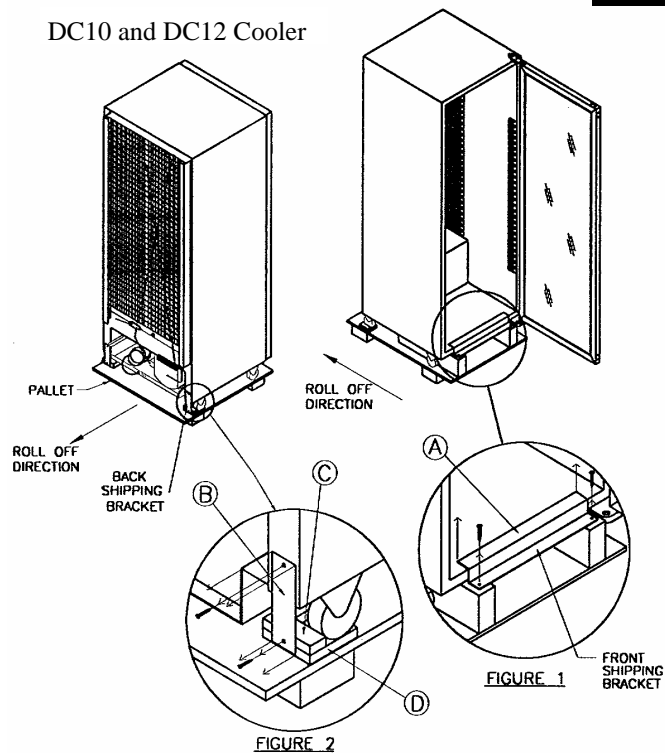

QBD^{ch!} DOOR HANDLE INSTALLATION INSTRUCTION



“2006 & BEFORE”

For Coolers Model
DC3, DC4, DC7, DC10, DC12, DC22, DC26.

1. Remove Handle Set from plastic shipping bag. Set consists of two mounting screw, Handle, Front cover plate and this Instruction Sheet.
2. Pull the door gasket away from doorframe, directly behind the two holes in the door-frame, by using fingers and hand strength only. See Fig. 1. **WARNING:** the use of hard or sharp tools may damage soft gasket material.
3. After removing the door gasket, the two 3/8" Dia. holes will be exposed. The two special screws provided in this kit are now inserted in the 3/8" Dia. holes. The door handle must be positioned such that two “D” shaped holes found in the rear-mounting surface of the handle are toward the edge of the door-frame. The screws must be threaded in the “D” shaped holes in the handle. See Fig. 2. **WARNING:** Only use a hand operated Phillips or Robertson (square socket) screwdriver to secure handle screw.
4. After securing the two rear-mounted screws the gasket pushed, by hand, back into it's retaining slot.
5. Insert front cover plate into slot in lower section of the handle, ensuring the dimple on cover lines up with notch on handle. Slightly bow out cover and insert opposite end into top slot, depress front cover into place by running fingers down full length of cover.
6. For removing the cover plate locate small hole on backside of the handle, by running fingers down. Inserts in the hole 1/8" Allen Key or similar sized object and push it slightly. Cover plate will pop out from main body

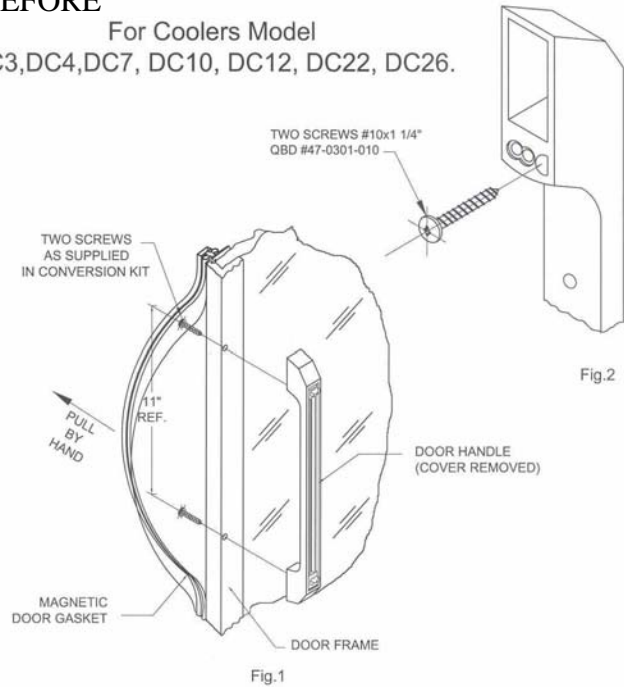

“2006 & ONWARDS”

1. Using Philips head screw drive remove both screws holding the door handle to the door trim as shown.
2. Remove door handle, in removal of door handle the inserts may fall out of the door trim. If this occurs, reinsert them as shown.
3. Tighten both screws until door handle is secure, Pull firmly out ward as you would open the door to confirm.

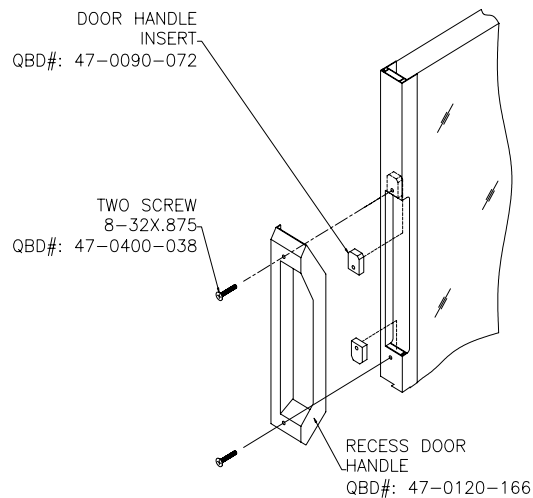

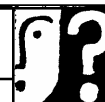
**USE THE PROBLEM SOLVER**

PROBLEM	POSSIBLE CAUSE
COOLER DOES NOT OPERATE	Not plugged in. The circuit breaker tripped, or fuse blown.
TURNS ON AND OFF FREQUENTLY	Wrong voltage supply. Unit set too close to the wall or other indirect heat source. Use of an extension cord. Cold control improperly adjusted. Faulty over load, start relay or cold control. Dirty Condenser.
SEEMS TO RUN TOO LONG	Check for proper clearances like unit too close to the wall. Frequent door openings let cold air escape. Check if any indirect heat source like sunlight. Dirty Condenser.
VIBRATIONS	If cooler vibrates, it probably is not level. Adjust front leveling legs.
CABINET HAS ODOR	Foods with strong odors should be tightly covered. Check for spoiled food. Interior may need cleaning. Keep an open box of baking soda in cooler, replace every three months.

**WHERE TO CALL FOR QBD SERVICE ...
HOW TO DO AWAY WITH SURPRISE REPAIR BILLS ?**

Your new visi cooler is a well designed and engineered product. Before it left the factory, it went through rigorous tests, just to make sure it was as problem-free as possible. And you have a warranty to protect you against any manufacturing problems during the period of your appliance warranty.

Now you can have the same trouble-free and surprise-free service for as long as you own your cooler. You can buy a QBD Service Contract. For one low fee usually just pennies a day QBD Customer Service will take care of the repairs your cooler needs - both parts and labour. You are protected for the length of your contract. Even when costs go up, you pay nothing more.

Want more information? There's no obligation. You can get information on Service Contracts any time. Just call or write to:

**Manager, QBD Customer Service,
QBD Cooling Systems Inc.
31 Bramsteele Road,
Brampton, Ontario,
Canada L6W 3K6.**

**Tel. 1(905) 459 0709, 1(800) 663 3005
Fax.1(905) 459 1478
email: info@qbd.com
www.qbd.com**

