

PROJECT:	QTY:	ITEM No.
-----------------	-------------	-----------------

WCXX81TH

SELF SERVE REFRIGERATED MERCHANDISER

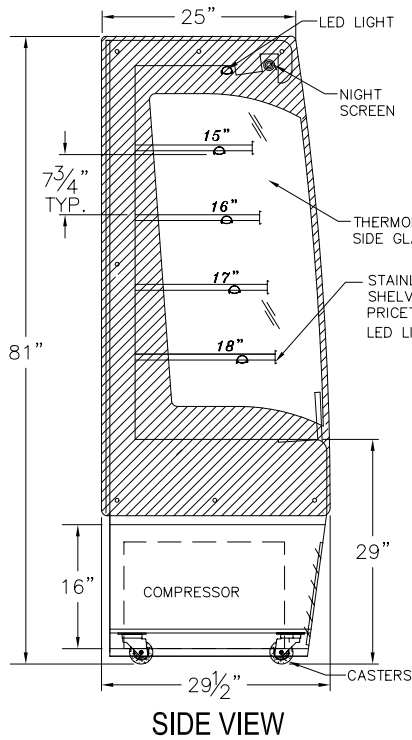

DISPLAY CASE MUST NOT BE LOCATED IN DIRECT SUNLIGHT OR NEAR SOURCES OF AIR FLOW INCLUDING DOORS, WINDOWS AND VENTILATION SYSTEMS.

* DISPLAY CASE MUST HAVE 6" CLEAR SPACE ON ALL SIDES INCLUDING TOP.

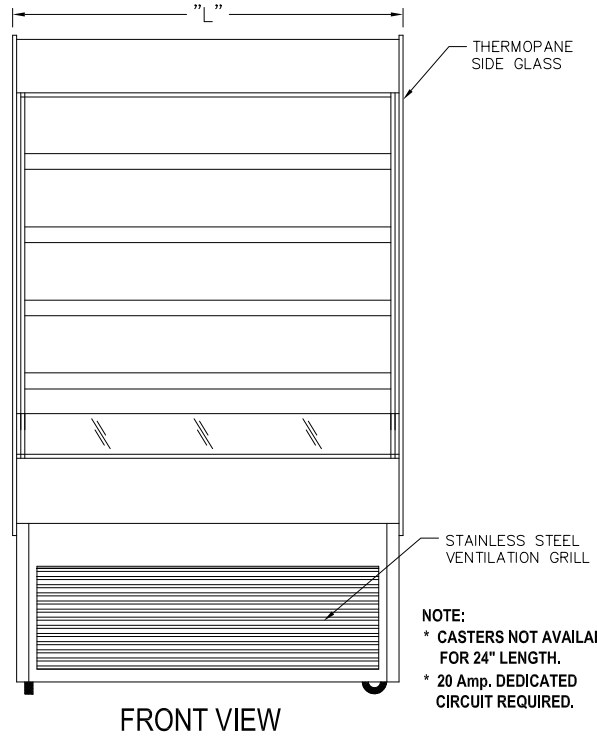

NEMA RECEPTICAL CONFIGURATION

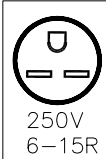

FOR COMPRESSOR & LIGHTS FOR WC4881TH

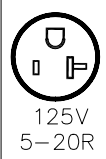

FOR COMPRESSOR & LIGHTS FOR WC2481TH & WC3681TH

SPECIFICATIONS

DIMENSIONS	WC	WC	WC	MODEL	MODEL	MODEL
	2481TH	3681TH	4881TH	No.	No.	No.
Length (in)	24"	36"	48"	L	L	L
Depth (in)	29.50"	29.50"	29.50"	D	D	D
Height (in)	81"	81"	81"	H	H	H
ELECTRICAL						
Voltage	120	120	220	120	120	120
Amperes (Compressor and Light)	13.6	13.6	10.0	Amps.	Amps.	Amps.
Amperes (Elect. Cond. Pan needs separate circuit)	DIRECT DRAIN	DIRECT DRAIN	DIRECT DRAIN	Amps.	Amps.	Amps.
Power Cord	8 ft.	8 ft.	8 ft.	8 ft.	8 ft.	8 ft.

NOTES

- All Specifications subject to change without notice.
- This Design is the property of QBD Modular Systems Inc. No copies or reproductions are permitted without the written permission of QBD Modular Systems Inc.
- ** All units are designed to operate under normal store conditions of 24°C (75°F) with 50% relative humidity, and maintain the temperature between 35°F to 40°F.
- **Condensation on glass may occur in Hot/Humid conditions.QBD is not responsible for any consequential damages as a result.
- **QBD WARRANTY DOES NOT INCLUDE PRODUCT LOSS OR CONSEQUENTIAL DAMAGES HOWEVER CAUSED.

Manufacturers of food service displays



QBD MODULAR SYSTEMS INC. TEL: (905) 459-0709
 31 BRAMSTEELE ROAD, BRAMPTON, ONTARIO, CANADA L6W 3K6 FAX: (905) 459-1478
WWW.QBD.COM info@qbd.com

DR. BY:	Dave
DATE:	11/16/12
FILE:	WCXX81TH